

BUILD YOUR OWN WIND GENERATOR



Table of contents



The Marriage!	3
Learn about Wind Turbines	8
Horizontal Axis Wind Turbines (HAWT).....	8
Vertical axis	11
Where should you place your wind turbine?	13
Dispelling wind power myths	15
How much power can you expect?	24
A quick guide to predicting energy capture	26
Should you buy or build a wind turbine?	27
A thing or two about generators	28
How do they work	31
What about Towers?	33
The Basic Types of Towers	34
Battery Basics	36
How to Charge.....	37
How to build your own Wind Turbine	38
Safety Considerations.....	38
Construction	41
Materials and supplies that you can use for the basic parts.....	42
Tool needed:.....	42
Step one: Acquire the Motor/Generator	42
Step 2: Building the Blades	44
Step 3: Sanding the Blades	46
Step 4: Getting Blades on to the Hub	46
Step 5: Protect the Generator	48
Step 6: Mount and Tail	48
Step 7: Balancing your blades	49
Step 8: Set up the Tower	50
The Mast.....	50
Tower Hinge	51
Gin Pole	52

Guy Wires	52
Yawing	54
Step 9: Wiring the system	54
Step 10: Connect the batteries and charge controller	55
Final Thoughts.....	56

The Marriage!

When I finished building my first solar system I felt like I was the king of the world. I had my best friend up there shining, my family as happy as they can be and everything seemed to work smoothly. But not long after, I started receiving letters from people saying: “Hey Ben, we could use more sun in here!”

The sun is great and I think we all agree to that at this point, but what if you live in an area where it doesn't show its face as long as you need? However, when the sun is out, the wind is blowing your head off!

Nature's got that covered, because for that, my friends, we have wind power. Wind is another viable, renewable energy resource that can provide electricity to our homes and businesses, while reducing our carbon footprint and the use of fossil fuels.

And while we were travelling around the country, we've met a lot of people using wind power.

Now, you probably already know that wind and solar systems complement each other very well and can be combined to increase your alternative energy supply. I call this - **The Marriage!** Because it's what it is. Wind and solar complete each other and work together like a husband and wife.

This Marriage idea came to me the day I met my friend Phil. He's a modern-day pioneer, a self-made man who has transformed his 50-acre property in Arkansas into a self-sufficient homestead. Over the last 2 years, Phil has converted a piece of raw land nestled in the beautiful Arkansas valley to a virtual oasis, complete with a 1,600-square-foot rock home, a 5-acre fish pond, and his own nine-hole golf course.



Phil has been in the machining business for 25 years: a trade that has helped him build and modify his independent energy system. When he took a serious look at his retirement options, he realized that his energy costs were disturbingly high and increasing every year.

The alarm bells started ringing, and he asked himself, “How can I get a better return on the investment in my new home, and plan for my energy future?” Phil set out to lower his energy bills. He started researching his options on how to provide the four main elements of his home energy needs—heating, hot water, cooling, and electricity. Here is how he did it.

As a first step, Phil set out to reduce his energy demand by insulating his home and shop thoroughly. The original house had wood siding with R-13 insulation. A 1-foot-thick stone facade was added to the home’s exterior, with a 1- to 2-inch (2.5–5 cm) gap between the rock and the original siding. Phil then built a large, south-facing screened porch overlooking the pond to manage the afternoon sun’s impact on his house, and provide a pleasant place to oversee his property.

He replaced his natural gas-fueled range, cook top, and clothes dryer with propane appliances that are supplied by a 100-pound (45 kg) propane tank, which usually yields a six-month supply. He continues to use these appliances sparingly along with his microwave, which had its clock disconnected to reduce the phantom load. All the lighting in his home and workshop is either compact fluorescent or tubular fluorescent for higher efficiency.

He has three ceiling fans and a 3-ton central air conditioner to cool his home. With the exception of the air conditioner, the electrical needs in the house are relatively modest.

In the 60- by 80-foot workshop, he has a full machine shop with lathe, mill, sharpeners, grinders, air compressors, and other assorted tools. These are used to maintain his golf course, and to fabricate the many innovations he has developed. The shop's electrical load can be large, but most of the time only one device is running.

A separate load center in the shop is fed from the main panel at the house. These two AC distribution panels are connected, and now his independent energy system feeds them both. An 18 KW diesel generator is used as a backup power source for battery charging, and to periodically assist large loads like the air conditioner, irrigation pumps, and shop tools.

After taking all these important steps, Phil thought he wanted multiple charging sources that would allow for some energy production in any weather condition at any time of day. He knew his energy needs, and was perfectly willing to manage them and his energy generation to achieve the goal of energy independence.

So he went hybrid! He started building solar panels one by one and moved on to the wind turbine which he built in a few hours. He did everything: putting the parts together, mounting the panels, installing the tower and wind generator, building the battery case and connecting everything, so that he can entirely rely on renewable energy.

Phil has also built a custom micro hydroelectric turbine to add to the energy mix. He chose components carefully to allow for maximum production and flexibility, and to provide for future growth of the system. A 48-volt system was chosen to keep system efficiency high and wiring costs low. After the system was installed and tested,

Today, Phil is proud to have pulled the plug on his utility service and enjoys both the independence and the responsibility of having a stand-alone renewable energy system:

“My lovebirds are working together day after day to give me the comfort and freedom that I need in my life. Now that’s what I call a successful relationship!”

And that’s how I got the idea of The Marriage! But right now, we need to concentrate on wind power and in just a few moments, I’ll show you how to build your first wind turbine.

Important Note:

Before you consider investing in a wind energy system, however, it is important to determine if your location offers sufficient environmental conditions to harvest



wind power. Just as you would not put a solar panel in the shade, you wouldn’t want your wind turbine in a low turbulence area.

To find out if wind power is suitable for your energy needs, you need to look again at your energy costs or the cost to operate your household or business appliances daily and wind speed.

There is a basic 10mph average wind speed rule that applies to the effectiveness of a wind energy system. If your property only experiences a breeze or two a day or rarely sees winds over 3mph, then a wind energy system may not be the best alternative energy system for you.

Learn about Wind Turbines

There are two basic types of wind turbines, determined by which way the turbine spins. Wind turbines that rotate around a horizontal axis are more common (like a wind mill), while vertical axis wind turbines are less frequently used (Savonius and Darrieus), however, my personal favorite.



Horizontal Axis Wind Turbines (HAWT)

Horizontal axis wind turbines, also shortened to HAWT, are the common style that most of us think of when we think of a wind turbine.

A HAWT has a similar design to a wind mill. It has blades that look like a propeller that spin on the horizontal axis.

Horizontal axis wind turbines have the main rotor shaft and electrical generator at the top of a tower, and they must be pointed into the wind.

Small turbines are pointed by a simple wind vane placed square with the rotor (blades), while large turbines generally use a wind sensor coupled with a servo motor.

Most large wind turbines have a gearbox, which turns the slow rotation of the rotor into a faster rotation that is more suitable to drive an electrical generator.

Since a tower produces turbulence behind it, the turbine is usually pointed upwind of the tower. Wind turbine blades are made stiff to prevent the blades from being pushed into the tower by high winds. Additionally, the blades are placed a considerable distance in front of the tower and are sometimes tilted up a small amount.

Downwind machines have been built, despite the problem of turbulence, because they don't need an additional mechanism for keeping them in line with the wind, and because in high winds, the blades can be allowed to bend which reduces their swept area and thus their wind resistance. Since turbulence leads to fatigue failures, and reliability is so important, most HAWTs are upwind machines.

HAWT advantages

- The tall tower base allows access to stronger wind in sites with wind shear. In some wind shear sites, every ten meters up the wind speed can increase by 20% and the power output by 34%.

- High efficiency - since the blades always move perpendicularly to the wind, receiving power through the whole rotation. In contrast, all vertical axis wind turbines, and most proposed airborne wind turbine designs, involve various types of reciprocating actions, requiring airfoil surfaces to backtrack against the wind for part of the cycle. Backtracking against the wind leads to inherently lower efficiency.

HAWT disadvantages

- Massive tower construction is required to support the heavy blades, gearbox, and generator.
- Components of a horizontal axis wind turbine (gearbox, rotor shaft and brake assembly) being lifted into position.
- Their height makes them obtrusively visible across large areas, disrupting the appearance of the landscape and sometimes creating local opposition.
- Downwind variants suffer from fatigue and structural failure caused by turbulence when a blade passes through the tower's wind shadow (for this reason, the majority of HAWTs use an upwind design, with the rotor facing the wind in front of the tower).
- HAWTs require an additional yaw control mechanism to turn the blades toward the wind.
- HAWTs generally require a braking or yawing device in high winds to stop the turbine from spinning and destroying or damaging itself.

Cyclic stresses and vibration

When the turbine turns to face the wind, the rotating blades act like a gyroscope. As it pivots, gyroscopic precession tries to twist the turbine into a forward or backward somersault.

For each blade on a wind generator's turbine, force is at a minimum when the blade is horizontal and at a maximum when the blade is vertical. This cyclic twisting can quickly fatigue and crack the blade roots, hub and axle of the turbines.

Vertical axis

Vertical axis wind turbines, as shortened to VAWTs, have the main rotor shaft arranged vertically. The main advantage of this arrangement is that the wind turbine does not need to be pointed into the wind. This is an advantage on sites where the wind direction is highly variable or has turbulent winds.

With a vertical axis, the generator and other primary components can be placed near the ground, so the tower does not need to support it, also makes maintenance easier. The main drawback of a VAWT is that it generally creates drag when rotating into the wind.

It is difficult to mount vertical-axis turbines on towers, meaning they are often installed nearer to the base on which they rest, such as the ground or a building rooftop. The wind speed is slower at a lower altitude, so less wind energy is available for a given size turbine.

Air flow near the ground and other objects can create turbulent flow, which can introduce issues of vibration, including noise and bearing wear which may increase the maintenance or shorten its service life.



However, when a turbine is mounted on a rooftop, the building generally redirects wind over the roof and this can double the wind speed at the turbine. If the height of the rooftop mounted turbine tower is approximately 50% of the building height, this is near the optimum for maximum wind energy and minimum wind turbulence.

VAWT subtypes

Darrieus wind turbine

Darrieus wind turbines are commonly called "Eggbeater" turbines, because they look like a giant eggbeater. They have good efficiency, but produce large torque ripple and cyclic stress on the tower, which contributes to poor reliability.

Also, they generally require some external power source, or an additional Savonius rotor, to start turning, because the starting torque is very low. The torque ripple is reduced by using three or more blades which results in a higher solidity for the rotor. Solidity is measured by blade area over the rotor area. Newer Darrieus type turbines are not held up by guy-wires but have an external superstructure connected to the top bearing.

Savonius wind turbine

A Savonius is a drag type turbine. They are commonly used in cases of high reliability in many things such as ventilation and anemometers. Because they are a drag type turbine they are less efficient than the common HAWT. Savonius are excellent in areas of turbulent wind and self starting.

VAWT advantages

- No yaw mechanism is needed.

- A VAWT can be located nearer the ground, making it easier to maintain the moving parts.
- VAWTs have lower wind startup speeds than the typical the HAWTs.
- VAWTs may be built at locations where taller structures are prohibited.
- VAWTs situated close to the ground can take advantage of locations where rooftops, mesas, hilltops, ridgelines, and passes funnel the wind and increase wind velocity.

VAWT disadvantages

- Most VAWTs have an average decreased efficiency from a common HAWT, mainly because of the additional drag that they have as their blades rotate into the wind. Versions that reduce drag produce more energy, especially those that funnel wind into the collector area.
- Having rotors located close to the ground, where wind speeds are lower due and do not take advantage of higher wind speeds above.
- Because VAWTs are not commonly deployed due mainly to the serious disadvantages mentioned above, they appear novel to those not familiar with the wind industry. This has often made them the subject of wild claims and investment scams over the last 50 years.

Where should you place your wind turbine?

Installing a wind turbine to reduce your energy costs is a great decision, but where to place it is something you need to be careful with. I need you folk to have all the necessary information available before getting into this project.

A wind turbine must be mounted in a good wind site, well above ground clutter in the strongest, smoothest winds. Wind site assessors begin the process of identifying a proper place for a wind turbine by determining the prevailing wind direction at a site.

Although winds blow in different directions at different times of the year, or even within the same day, they arrive from one or two directions predominantly over the course of the year. In many places in North America, winds come predominantly from the southwest — thanks to the Coriolis effect. They often blow from the northwest in the winter.



To determine the predominant wind flow, ask the advice of farmers, who work outdoors and hence are familiar with wind patterns, or contact a local airport. They may be able to provide you with a wind rose, a graphical representation of wind direction. In a wind rose, the length of the spokes around the circle is an indication of how frequently the wind blows from a particular direction. The longer the line, the greater the frequency.

In a wind rose, the winds blow predominantly from the southwest. A wind rose also indicates the percentage of total wind energy from each direction, which is very helpful. You can also find data on wind direction at the [NASA Surface Meteorology site](#).

In an open site, with little ground clutter, a wind turbine can be located almost anywhere — so long as the entire rotor is mounted 30 feet above the tallest obstacle within a 500-foot radius and you've taken into account future tree growth, if trees are the tallest objects.

Unfortunately, very few of us live on ideal sites. There are almost always some major obstacles.

To identify the proper place for a wind turbine, first determine the prevailing wind direction. Then look for a location for the tower that's up wind of major obstacles. Although winds will shift so that upwind temporarily becomes downwind, situating your wind turbine and tower this way will ensure that it can take advantage of the strongest prevailing winds.

If you're determining where you are going to place your wind machine, it is also a good idea to minimize wire runs from the turbine to the controller and inverter to reduce line loss. As a rule, the higher the wind turbine's voltage, the farther it can be sited from the point of use. When installing a turbine, contact the manufacturer or an experienced installer for recommendations.

Dispelling wind power myths

Yeah, wind has been the victim of so many controversies. But you know what? It's all gossip, with no rational arguments. Instead, I've the arguments against. Hopefully, I'll convince you that wind power is not only worth it, but it is highly recommended.

“Wind doesn't work”

One reason given for not wanting to use wind power is that the equipment apparently doesn't work. "I drove past this wind generator and the blades weren't spinning." Well, maybe the wind wasn't blowing, or maybe it was blowing too hard. Maybe the wind system was shut down for routine maintenance. Maybe the owners' batteries were charged up and the power was not needed.

Maybe...I could go on and on, but I'm sure that you get the picture. We humans are very visual yet blind creatures in that first impressions are often the most lasting impressions. When one glances quickly at a PV array, a solar hot water heater, or even a hydro plant, you have no idea if it's operating or not. You can't see what's going on inside. But it is always obvious when a wind generator is or is not operating.

This isn't to say that wind generators always work. In the late '70s and early '80s, there were scores of companies who set up shop building wind generators. In many cases, their motivation was greed. They were attempting to cash in on the 40% federal tax credit that was granted to buyers of renewable energy equipment. Most states also offered tax incentives for these purchases. Homeowners could get up to 70% of a \$10,000 investment back from the government.

The problem was that there were no standards for most of the equipment that folks bought. Consumers were in the mood to spend lots of cash, and manufacturers were all too willing to take their money. No standards, lots of money, and the tax credits all combined for what would ultimately be a major setback for renewables.

There is no question that a lot of junk was being sold. Well, things have changed. People have learned about renewable energy. They know exactly what a wind generator is and what it takes for it to work.

“No Power!”

Many folks have the misconception that there is no real power available in the wind. Therefore, why bother with a wind generator. Let's look at this more closely. The equation for determining the power available to a wind generator is as follows: $P = 1/2 \rho A V^3$ where P is the power in the wind, ρ is the density of the air, A is the swept area of the rotor, and V is the wind speed or velocity.

What we are interested in here is V^3 or $V \times V \times V$. When we double the wind speed for a given location, say from 5 to 10 mph, we increase the value of V^3 by a factor of eight!

Multiply $5 \times 5 \times 5$ and you get 125. Double it to 10. Multiply $10 \times 10 \times 10$ and the result is 1000, an 800% increase.

There are two lessons here. The first is that even small gains in wind speed can result in enormous increases in the power in the wind. As the wind steadily increases, the power in the wind increases exponentially.

The second lesson is that, because the power gets so large so fast, it must be awfully difficult to build a wind system that will survive high winds. Any do-it-yourselfer who has tried to design a wind generator has learned this lesson, probably the hard way. Of course, now we know this and we don't have to worry about it anymore.

“No Wind?”

A lot of people have the idea that wind power is so site specific that they probably have little or no wind at their site. Trust me! Many of them now have more power than they oftentimes know what to do with!

The chief culprit here is that wind power has been saddled with a very poor yardstick: average wind speed. Dealers will ask a prospective buyer what their average wind is. If it's down around eight or nine miles per hour, the dealer will usually disregard the wind system in favor of solar panels (PVs). But average wind speed is sometimes the wrong question to ask. An example is in order.

Let's assume two locations, each with an average wind speed of 10 mph. We are only interested in the average for one month, and we are going to take readings on a weekly basis. The wind speeds for our two imaginary sites are as follows:

Wind Speed for two Sites

	<i>Site 1</i>	<i>Site 2</i>
Week 1	10 mph	0 mph
Week 2	10 mph	0 mph
Week 3	10 mph	40 mph
Week 4	10 mph	0 mph
Monthly Average	10 mph	10 mph

While both sites have the same average, they have not been created equal! Let's develop the example a little further.

Remember the power equation, $P = 1/2 \rho A V^3$? Let's plug in the weekly values for wind speed from sites one and two, and then

add them up to determine the monthly value for V3. Note that the units for the numbers don't matter here. What we are interested in is the numbers themselves.

Obviously, when we plug the value of V3 into the power equation, 64,000 times something is going to be a lot more than just 4,000 times that same thing. While both sites look the same with regard to their average wind speeds, one site has a lot more fuel than the other!

Wind Speed cubed for two Sites

	<i>Site 1</i>	<i>Site 2</i>
Week 1	$10 \times 10 \times 10 = 1000$	$0 \times 0 \times 0 = 0$
Week 2	$10 \times 10 \times 10 = 1000$	$0 \times 0 \times 0 = 0$
Week 3	$10 \times 10 \times 10 = 1000$	$40 \times 40 \times 40 = 64,000$
Week 4	$10 \times 10 \times 10 = 1000$	$0 \times 0 \times 0 = 0$
Monthly Total	4000	64000

Even though your site may appear to be poor for a wind system based on the average wind speed, a low average wind speed is not enough in and of itself to disregard a wind installation.

Another major problem with the average wind speed readings that we have for the vast majority of the U.S. is that these averages are not representative of our wind resources. Wind speed data is usually collected by people like the National Weather Bureau or a local airport.

The trouble lies in the location and height of the recording equipment. Weather bureaus are interested in wind speeds at street level, where the people are. But wind generators live 80 or so feet up in the air, far above ground level obstacles and turbulence. A similar situation exists with airports.

Traditionally, airports were located in sheltered areas, because, traditionally, airplanes had trouble coping with cross winds when landing. While modern jets and planes have much less trouble with the wind, we're still stuck with wind speed readings from traditional airport locations. Airports don't spring up like strip malls.

The bottom line: average wind speeds at hub height, the height where the wind generator will be installed, are always substantially higher than those recorded by weather bureaus and airports.

“For how long?”

We have been told that to get a reasonable idea of the wind resource for a given location, the site must be monitored for at least a year. Longer, if possible. But why bother, you say. After all, if you have to wait a year to see if you even have any wind, why not just install PVs? This seems reasonable.

All you need to do is look in a book to find what the weather bureau tells you it's your solar resource. This is nonsense! All this kind of talk does is dissuade one from even considering a wind system.

There is a way to make weather bureau and airport data useful. Let's say you were to install a recording anemometer at your site and take daily readings for a month. During that month, you also called the weather bureau or airport for their readings once or

twice a day. At the end of the month, you would see a relationship between your data and their data.

As a matter of fact, you could extrapolate your data as far back as you wanted to, using the relationship between the two sets of data. You now have an excellent set of numbers describing your site's wind resource.

In order to make these numbers useful, the readings that you take at your site must be at hub height. This may entail getting up 60, 80, or 100 feet. Remember, wind generators spend their lives up above the trees and buildings, out of the turbulence. Taking the data at roof top level is about as useful as relying on weather bureau readings.

“Not Reliable”

Photovoltaic converts often point to the arrays and ask how a wind system can possibly compare to solar panels for reliability. After all, PVs have no moving parts. There are wind systems out there that are just as reliable as PVs. Let's look at a few examples.

I recently took down a Jacobs wind generator that had been in service for nearly 60 years. At one point it had been moved from one farm to another. At that time the bearings were replaced. One blade was replaced after being hit by lightning. And periodically, the brushes were replaced. Sixty years of service is why the old Jakes have earned the reputation as being the “cadillac” of wind generators.

“Expensive”

Another criticism leveled at wind is that the systems must be expensive because a generator has to be installed on a tower. The tower is certainly an added cost. However, when one compares the costs of a wind generator tower with a PV array tracker, an interesting fact arises. For a given generating capacity, say 3 kW of PVs versus a 3 kW wind generator, towers come in at approximately the same cost as trackers.

All of the other system components used — the batteries, the wire runs, the inverter, the switches, fuses, and disconnects — will be identical in cost no matter what electron generator is employed.

The real cost advantage is with the wind generator itself. Wind generators are 20–40% of the cost of PVs, watt for watt, depending on the economy of scale — the size system you buy. The exception is very small “micro” wind generators.

“Too Erratic”

Wind has often been criticized as being too erratic and inconsistent. No argument on this one. Well, maybe a little bit of a disagreement. The sun is pretty predictable. It comes up every morning, and goes down every night. You can bank on that one. The wind comes and goes. You never know when it might blow. But the wind is more predictable than you might realize at first. After all, the wind is a form of solar energy.



“Capacity factor” is a term used by electric utilities for comparing different generating technologies. The term refers to the amount of time that a given generator type is producing its kilowatts compared to the total time available for production.

For example, let’s say you live in an area with an average of 4 peak hours of sunlight for PV production. Since there are 24 possible hours of production available in a given day, your PVs would have a capacity factor of 4 divided by 24, or a 16% capacity factor.

Annual average capacity factors for fixed PVs in the lower 48 run from about 8% to about 25%. That number can increase for the northern tier of states by about half with the addition of a tracker. In comparison, annual average capacity factors for wind generators range from 10% to about 28%. Taller towers can do for wind what trackers do for PVs.

While the weather bureau does a poor job with average wind speeds, daily and seasonal wind patterns are very well documented. For about 90% of the U.S., the wind is quite noticeable during the fall, winter, and spring. During the summer, the wind ceases to exist in many places.

When you think about it, the wind usually blows when the sun doesn’t shine. And the sun is usually really bright when the wind isn’t blowing. These daily and seasonal patterns exist for the bulk of the U.S. Maybe we’re onto something here!

Comparisons

Let’s look at some of the advantages and disadvantages of the two technologies:

PVs advantages include:

- No moving parts. This is PVs trump card, by far.
- They are fixed on the ground or on the roof. No dangling from 80 feet in the air when it's time to remove dirt or bird droppings.
- They're modular. If you don't have enough capacity, just add a few more panels. You can't do anything like this with a wind system. If you need more wind capacity, you get a bigger wind generator, or install a second unit.

PVs only disadvantage:

- Cost! PVs are, by far, the most expensive of the renewable energy technologies. Well, unless you have the instructions to build them yourself, which we do, right?

Wind power's advantages include:

- Cost. It is one of the more cost-effective renewable energies, coming in behind only solar hot water heating and some hydro electric generators. Of course, when you build it yourself, the cost drops dramatically!
- More power in the resource. Because of the cube law, $P = 1/2 \rho A V^3$, wind generators can deliver awesome amounts of electricity in a brief period of time. For the folks with batteries, that means it's equalize time.

How much power can you expect?

And right here, I mean strictly with homemade wind turbines:

Wind speed	5mph	10mph	20mph	35mph
4 FT	.9 Watts	6.8	54.5	292.2

(1.21m)Blade Dia				
6 FT (1.82)Blade Dia	1.9	15.3	122.7	657.4
8 FT (2.43) Blade Dia	3.5	27.7	221.7	1188.3
10 FT (3.04) Blade Dia	5.5	43.7	349.9	1875.2

This table can give you a general idea what you might produce with a wind turbine. It assumes a conservative power coefficient (CP, efficiency of the system) of 15%, small commercial built turbines could be as much as double CP.

This table can help you to predict how much power you will be able to generate with a wind turbine. You need to take into account the size of your blades and the speed of the wind. The table assumes that your wind turbine will catch 15% of the raw power in the wind. This percentage is known as the power coefficient (CP).

The raw power in the wind depends on the density of air, the speed of the wind, and the diameter of your blades. Wind speed is the critical component though, the energy in wind velocity increases by the cube! That means the power in the wind will increase dramatically with wind speed.

The swept area of a wind turbine is the area in which the blades (propeller, wing, catch spoons, or sails) spin and catch the wind. So the bigger the blades the bigger the swept area, area is always square, so increasing your blade size will also dramatically increase your energy.

As you can see the power in the wind varies enormously. There are only a few watts available in light wind and huge amounts under high wind. It is not easy or sometimes even practical to design a machine which can convert the wide range of power effectively, so you should design it to handle medium or your average wind.

The wind is always changing, and the power fluctuations can be extreme. We need to harvest the energy when it is here and then store it for the calm periods. It is also a good idea to have some power source as a backup. Generally small wind electric systems use lead acid battery, which stores our surplus power during windy days and during the calm periods we can draw from that power.

[A quick guide to predicting energy capture](#)

Energy capture in a given time is the average power multiplied by the hours.

Here are just general averages of different sites, the higher you got up the faster the wind is.

Site	Average Wind Speed
Trees and Buildings	6 MPH
Large Open Field	10 MPH
Hilltops or Coast lines	13 MPH

Average power output from a wind turbine is not the same as its instantaneous power output when wind speed is average. I recommend calculating it yourself, using this equation:

Wind Turbine Power Equation:

$P = 0.5 \times \rho \times A \times C_p \times V^3 \times N_g \times N_b$ where:

P = power in watts (746 watts = 1 hp) (1,000 watts = 1 kilowatt)
 ρ = air density (about 1.225 kg/m³ at sea level, .9 kg/m³ at 4000 ft less higher up)

A = rotor swept area, exposed to the wind (m²)

C_p = Coefficient of performance (.59 {Betz limit} is the maximum theoretically possible, .35 for a good design)

V = wind speed in meters/sec (20 mph = 9 m/s)

N_g = generator efficiency (50% for car alternator, possibly 70% more for a permanent magnet generator, home made generator 50%)

N_b = gearbox/bearings efficiency (depends, could be as high as 95%)

Should you buy or build a wind turbine?

The simplicity of wind turbine/wind energy systems is so great that it can make the decision to buy or build a tough one. The first thing to understand when you are making this decision is that all wind energy systems have the same basic components. They all have blades, a generator, a mounting, and tower and control system.

The difference in between purchased prefabricated wind turbines and those that you can make yourself is going to be in the aerodynamics. If you are planning to supplement the majority of your home's energy needs then it more likely that you should look into prefabricated turbines.

If you are simply looking to reduce your energy dependency, more so than eliminate it, or to supply an outbuilding or pond with electricity, then a do-it-yourself wind energy system may suffice.

For those of you who are looking for a wind energy system that can supply your whole home with electricity, you will need a rather large turbine system that starts at around \$5,000 and easily exceed \$25,000. This depends on where and how you purchase your system. These systems will generally reduce your utility bills by around 70% and will usually show a return on investment in about 10 years. Not very convenient.

The best thing you can do is build your own wind turbine and then marry it to your solar panels.

A thing or two about generators

There are many different kinds of generators that could be used in a wind turbine, right now I am going to just group them in three different types.

Induction Generator

An induction generator is a type of electrical generator that is mechanically and electrically similar to an induction motor. Induction generators produce electrical power when their shaft is rotated faster than the synchronous frequency of the equivalent induction motor.

Induction generators are often used in wind turbines and some micro hydro installations. Induction generators are mechanically and electrically simpler than other generator types. They are also more rugged, requiring no brushes or commutator.

Induction generators are not self-exciting, meaning they require an external supply to produce a rotating magnetic flux, the power required for this is called reactive current. The external supply can be supplied from the electrical grid or from the generator

itself, once it starts producing power or can you can use a capacitor bank to supply it.

The rotating magnetic flux from the stator induces currents in the rotor, which also produces a magnetic field. If the rotor turns slower than the rate of the rotating flux, the machine acts like an induction motor. If the rotor is turned faster, it acts like a generator, producing power at the synchronous frequency. In the United States it would be 60hz.

The common down side of using an induction generator in a wind turbine is gearing. Typically you need an induction motors to run 1500+ RPM to meet the synchronous so a gearing is almost always needed.

Permanent Magnet Alternators

Permanent magnets alternators (PMA) have one set of electromagnets and one set of permanent magnets. Typically the permanent magnets will be mounted on the rotor with the electromagnets on the stator.

Permanent magnet motor and generator technology has advance greatly in the past few years with the creation of rare earth magnets (neodymium, samarium-cobalt, and alnico). Generally the coils will be wired in a standard three phase wye or delta.

Permanent magnet alternators are can be very efficient, in the range of 60%-95%, typically around 70% though. As a generator they do not require a controller as a typical three phase motor would



need. It is easy to rectify the power from them and charge a battery bank or use with a grid tie.

It is easy to build a permanent magnet alternator, even for beginners. This is a common choice for home builders. I will have some great information on this site a little later that will take you through the design and building process. You just need to understand a little science and have some sort of mechanical competency.

Note: Car alternators are not PMA but actually have a field coil instead of permanent magnets, and are typically very inefficient around 50%. They typically need to be spun 1500+RPM to get any real power out of them, but with a belt or gear arrangement can still do a decent job.

Brushed DC Motor

Brushed DC Motors are commonly used for home built wind turbines. They are backwards from a permanent magnet generator. On a brushed motor, the electromagnets spin on the rotor with the power coming out of what is known as a commutator.

This does cause a rectifying effecting outputting lumpy DC, but this is not an efficient way to “rectify” the power from the windings, it is used because it’s the only way to get the power out of the rotor. A good brushed motor can reach a good efficiency, but are typically at most 70%.

There are many great advantages to using a brushed motor. One of the biggest reasons is because typically you can find one not requiring any gearing and still get a battery charging voltage in light wind. They are also quite easy to find, they can be purchased

from eBay, surplus supply stores, industrial supply stores, and can find them on different things that might get thrown away or given away (like a treadmill).

How do they work

Let's cover some information on how a permanent magnet generator works. Some of you might refer to these as permanent magnet alternator (PMA). The two most important things to know about in a generator are the magnets, which typically make up the rotor, and the electromagnets or coils that make up the stator.

Stator and Rotor, What are they?

Just to cover the basics, the stator stays and the rotor rotates. The stator is generally the housing on a radial flux motor. A pancake motor/generator is axial flux where half of the generator spins and the other 'pancake' is the stator.

Magnets

A magnet has two poles, we commonly call them north and south, just like the earth magnetic poles. Magnets emit what we call magnetic flux and it flows from the North Pole to the South Pole.

Flux flows or moves better thru iron than open air. Iron can direct magnetic flux, and this can be very useful when designing a generator. However, the flux must flow back to the magnet just like electricity and we call this the magnetic circuit.



Most PMA use rare earth magnets - neodymium are the strongest and the most common choice. Neodymium magnets range in strength up to N65. The stronger the magnets, ultimately the stronger the flux field hitting the electromagnets, the higher the voltage they will produce at any given RPM.

Electromagnets

Electromagnets, sometimes referred to as coils, are split into two categories, iron cores and air cores (ironless). Iron cores are most common and highly used commercially. The iron can help intensify your magnet flux field by directing it and putting it to better use, increasing your efficiency. Air cores have no core material and are just a wrap of wire.

Air core motors are just starting to be made with higher efficiency than those with iron cores; they do not have iron losses which make up the difference. Most of you interested in building a generator will start with an air core design, they are restively easy to design and if you do a good job it is possible to hit 60%, but typically I see anywhere from 30%-60% from homemade models.

What do the electromagnets do? When the permanent magnets are passing by creating an alternating flux field, this 'excites' the coil and a current is induced in the coil. Current is the real power, the voltage is the speed/force that the current has. The voltage is reversed with each change of polarity of the permanent magnet. This is why it produces A/C (Alternating Current).

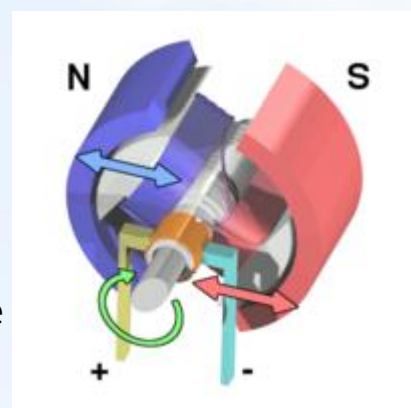

The windings of the coil are very important to what power and voltage you want to create. First you need to determine your desired voltage, max current, and speed.

The more wraps on the coil the higher the voltage will be produced with lower current, the few wraps would be a higher current while lowering the voltage. The power coming out remains the same, typically more wraps means more wire, more wire means more resistance, just keep that in mind.

Air Gaps and Flux

You are going to have to have some sort of gap between your stator and rotor as to allow them to spin. As I mentioned before magnetic flux does not travel through air the very well, we will refer to this as magnetic resistance.

The smaller the air gap the less resistance and the higher the efficiency. Also you can use this to increase or decrease your voltage. Moving the stator further away from the rotor will decrease it, moving them closer together will increase your voltage.

What about Towers?

Don't under estimate the importance of the tower. Many people will over look the trouble of building a tower. Building the tower can be the biggest part of this project and potentially the most dangerous. There are many different kinds of towers and structures you can build to support your wind turbine. If you don't feel comfortable building or erecting your own tower then I recommend purchasing one. You can find them in nice affordable kits that will make putting them up much easier, or you can have a contractor do it.

Location

Before going ahead and choosing a tower design let's talk about location. It's a good idea to study the potential site(s) to find the best one for that area. You want to find a good open area that is free from obstacles that would block the wind. The higher up you go, the faster the wind blows which increases the power to your wind turbine greatly.

You might also want to purchase anemometer and average the wind speed at different heights. All of this data is a great resource when sizing your rotor and generator.

You will also need good ground to build a solid foundation for the tower. Local laws are also important to consider, contact your city or country office for the code that may relate to a wind turbine.

The Basic Types of Towers

Free Standing Tower

A free standing tower has a single mast and requires no additional support. Most commercial wind turbines use free standing towers. Will have a large steel mast and require a deep foundation. These will normally require to be erected by a crane. If you are interested in having a free standing tower, and are not a professional, I recommend purchasing one.

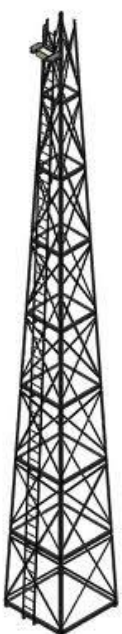

Lattice Tower

Lattice tower were common back in the old farm days, they are kind of towers you see most wind powered well pumps on. They have a larger foot print for their size requiring a larger foundation.

They are supported by three or four legs with interlock braces up and down the tower. This type of tower is a good option if you are looking for a small and cheap wind turbine tower.

Guyed Tower

A guyed tower has a center pole with guyed wires supporting and holding it in place. You will typically find guyed towers for radio and television antennas. These towers are typically the easiest and cheapest to build. However, they are ugly and intrusive and require more space than a free standing tower.



Tilt-up Guyed Tower

Tilt-up towers are nice for erecting and maintaining and are the most popular for home wind turbine builders. They have a pivot at the bottom allowing them to bend up and down from the ground. A tilt-up guyed tower is a popular choice for home builders. I do want to issue some caution while raising and lowering a tower, a large amount (greater than the weight) will be placed on the mast. Plan ahead, do it slowly, and make sure everyone is in a safe location while raising and lowering.

Gin Pole

Some tilt up towers have what is known as a gin pole, which is perpendicular to the main mast. This arm is used to help lift the tower off the ground. Usually it is a steel pipe of the same diameter as the tubular tower pipe. The longer the gin pole, the easier it is to lift the tower. A gin pole makes it much easier to raise the tower but not completely necessary.

Battery Basics

Lead acid batteries are the oldest type of rechargeable battery. They are the easiest battery to maintain and typically are the lowest costing making them the idea battery bank for home solar/wind systems.

This page is going to talk mainly about 12 volt flooded lead acid, but it applies to all you will just need to multiply or divide the voltages. 12 volt lead batteries are made up of 6 cells, each cell voltage is about 2.15v. A 24 volt battery would have 12 cells at 2.15v.

What is a full charge and what is a full discharge

A fully charged lead acid battery will be at 12.6v at 70° F, this is the sitting open circuit voltage, meaning that it has not been charged or had a load in at least several hours. If the battery is charging the voltage will float higher and if there is a load on the battery the voltage will float lower. To get an accurate reading of the battery it must be disconnected and left to sit for about a day.

This also applies if you are using a hydrometer to measure the specific gravity.

If you need to get a quick reading while charging, simply disconnect the battery and wait a few seconds and if the battery is still above 13.2v then you can assume it is near a full charge.

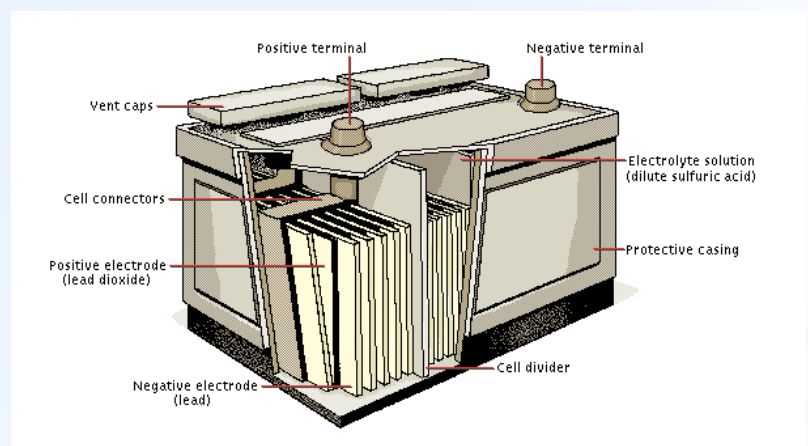

How to Charge

Charging a lead acid battery is easy, just give it more than 2.15v or high per cell, the higher the voltage the faster the charge. The charging voltage must always be higher than the battery voltage, voltage is a force, so you need to have a higher force coming from your charger to push the energy into the battery.

Typical charging voltages for a 12 volt battery are between 12.9v and 14.4v, these voltages will completely charge the battery without overcharging or damaging the battery. If the battery is not near being completely charged you can charge at a much higher rate without causing any damage.

Many modern chargers use multiple charging stages to allow the battery to charge quickly, efficiently, and completely without damaging the battery. These stages are typically broken down into the following three stages:

Bulk Charge – The first stage where most of the battery is charged to around 80 or 90%. A high voltage is applied to the battery; there is no typical range for doing a bulk charge, but typically between 10.5v to 16v. The charger would wait until the battery rose to a predetermined voltage typically between 12.6v and 13.5v.

Absorption Charge – The second stage is where the battery is 'topped off'. A constant voltage is applied generally between 14.1v and 15v. Current will gradually taper off as internal resistance increases during charging. The charger will wait until the battery voltage rose to a predetermined voltage typically around 14v.

Float Charge – The final stage of these chargers is to 'float' the battery at a voltage that will keep it fully charged and ready for use, it will also help to prolong the life of the battery. After the

absorption charge is complete the voltage will be dropped to around 12.8v to 13.8v. This is sometimes referred to a trickle charge.

Many of the modern chargers use PWM (pulse width modulation) that pulses the power to battery only a percent of the time proportional to the charging voltage several hundred or thousands of times a second. This accomplishes the same thing as regulating the voltage.

How to build your own Wind Turbine

I know I've kept you waiting, but we're almost there. Before we get into the building process, I need you to carefully read and respect the following safety guidelines.

Safety Considerations

- Workshop safety depends on correct behavior. There are intrinsic dangers. Be aware of the risks to yourself and others and plan your work to avoid hazards. Protective clothing will reduce the risks, but without awareness the workshop will not be safe.
- Keep the workshop tidy. Avoid trailing leads, precarious buckets or other unnecessary hazards, which people could trip over or spill.
- Watch out for others, to avoid putting them at risk and beware of what they might do which could put you at risk.
- Wear protective clothing - eye protection, gloves, helmet,

mask, etc as appropriate to prevent danger. Avoid loose clothing or hair, which could be trapped in rotating tools and pulled inwards.

- Take care when handling tools which could cut or injure yourself or others. Consider the consequences of the tool slipping or the work piece coming loose. Attend to your work, even when chatting to others.
- Grinding, sanding, drilling etc can produce high velocity dust and debris. Always wear a mask when grinding. Take care that any sparks and grit are directed into a safe zone where they will not injure anyone, or cause fires. Consider how the tool might come into contact with fingers or other vulnerable body parts.
- Welding, drilling etc makes metal hot, so take care when handling metalwork during fabrication.
- Welding should take place in a screened space where the sparks will not blind others. Wear all protective clothing including mask. Do not inhale the fumes. Protect the eyes when chipping off slag. Do not touch live electrodes or bare cable.
- Steel mechanisms can fall or fold in such a way as to break toes or fingers. Think ahead when handling steel fabrications to prevent injury. Clamp the work piece securely.
- Take great care when lifting steel assemblies, to avoid back injury. Keep well clear of towers and poles that could fall on your head. Wear a safety helmet when working under wind

turbines.

- Take care with sharp tools. Clamp the work piece securely and consider what would happen if the tool slips. Watch out for others.
- Wear a dust mask when sanding. Do not force others to breathe your dust. Take the job outside if possible.
- The solvents in resins can be toxic. Wear a mask and make sure there is adequate ventilation.
- Avoid skin contact with resins. Use disposable gloves. Plan your work to avoid spillage or handling of plastic resins and glues. Be especially careful of splashing resin in the eyes.
- Magnets will erase magnetic media such as credit cards, Sim cards, camera memory cards, and damage watches. Remove suchlike from pockets before handling magnets.
- Magnets fly together with remarkable force. Beware of trapping your fingers. This is the most likely cause of small injuries. Slide magnets together sideways with extreme caution.
- Magnets can slam together with great force. As they are brittle in nature they can often peel, crack or shatter and send shards of magnets flying all over the place, so wearing eye protection is essential.
- Check for dangerous voltages before handling any wiring.

- Battery voltage systems are mostly free from dangerous voltages, but there is a shock hazard from wind turbines running disconnected from the battery. Under these conditions the output voltage can rise to dangerous levels.
- Even at low voltages there is a danger of burns from electric arcs or short circuits. All circuits from batteries should have fuses or circuit breakers to prevent sustained short circuits causing fires.
- Be especially careful with batteries. Metal objects contacting battery terminals can cause large sparks and burns. Gas inside the battery can be ignited, causing an explosion that spatters acid in the eyes. Acid will burn clothing and skin. Avoid contact, and flush any affected parts with ample water. Take care when lifting and moving batteries to prevent back injury or acid spills.

Construction

There is nothing more rewarding and empowering than making a wind powered generator from scrap materials. Wind power is one of the abundant, clean, inexpensive, renewable, and easy to use resources.

Most of the tools and materials that will be required to make your own wind turbine similar to this one can be found at your local hardware shop or junk pile. These are the five basic parts to a wind turbine:

- A generator
- Blades
- A mounting that keeps it turned into the wind

- A tower to get it up into the wind
- Batteries and charger controller

Materials and supplies that you can use for the basic parts

- Motor to use as a Generator or a Generator
- Large plastic pipe 4" + - to use as blades
- Square metal tube for the base
- Couple pieces of scrap metal
- Nuts and bolts
- Pipe or pole to use as the tower

Tool needed:

- Power Drill and Drill Bits
- Straight edge (ruler) and Pencil
- Jigsaw (band saw)
- Compass and protractor
- Wrenches
- Socket Set
- Screws
- Protective equipment

Step one: Acquire the Motor/Generator

The generator is the core of your wind turbine. We will be using it to generate the electricity. Most motors can produce electricity when spun. Some are slightly more complicated than other though. The best kind of motor is permanent magnet brushed or brushless motor.

Permanent magnet types work well as generators. Also, they don't normally require high RPMs to get some usable power out of them. To find out if your motor or generator will work, look on the label and find the RPM. Then, find the working voltage. Divide

RPMs by voltage to get RPMs per volt. This is known as your (k of v).

For a small wind turbine you are looking for something around 25 RPM per volt. The more RPM per volt, the faster wind turbine will need to turn to charge a battery, which means you will need faster wind before it will start charging.

One of the most popular motors to use is the Ametek 30, its works great, it was an old computer tape drive motor.



Those Ametek's are not very easy to find now and not very cheap. I found myself a good treadmill motor off eBay and I recommend you do the same. Not all treadmill motors will work good in low wind. Mine was rated for 1700 RPM at 260 volts or .15 Volt per RPM. This means that the motor will have to spin at least 80 RPM to get 12 volts out to charge my battery. My motor also came with screw on hub.

Hopefully the motor you choose has a hub attached. If it doesn't, you'll have to find something else that works. Circular saw blades, HDPE plastic, piece of scrap metal, pulleys, and hubs from something else might work, but remember your wind turbine can get up to several hundreds RPM, so whatever you choose get that hub on tight and secure!

The motor should be easy to turn by hand, and it should produce a bit of voltage with a hand turn. Something in the range of 1-2 volts with a hand turn will be great. If in doubt, hook the motor to a

lathe, or drill press, or another motor to get a good representation of what it will output at a set speed. If the machine can't get voltage out of it, neither will the wind.

Step 2: Building the Blades

The blades I made are designed to be cheap and easy to make. My suggestion is to use the thickest material possible, and if it's vulnerable to UV damage, like PVC, paint it.



I recommend making your blades from 5" or 6" pipe, ABS or PVC. I have also heard that green sewer pipe that is 3/8" thick makes great blades that are durable. If you want to do nice ones, I recommend making out of fiberglass, much stronger. I would make a simple mold and use a foam core, use about 6-10 layers of woven glass.

Before choosing your blade design and material think about your average wind, light breeze, strong wind, hurricanes. You will get a lot more out of your wind turbine if your blades are designed for your kind of wind. As a general rule longer blades will help start the generator at lower wind speeds, but the output on the high end will be lower.

Also the longer the blades the less the speed (RPM) they produce, so in 5 MPH wind 20 in blades may spin at 80 RPM as 10 in blades spin at 130 RPM. If you only get small breezes, then make your blades wide and long, and maybe add an extra one. If you get

hurricane winds every day, keep the blades short and thin, and you will easily produce a lot of power with that wind turbine.

Making PVC/ABS Blades

These instructions are for 24" blades made out of 4in ABS pipe.

If you are using black pipe, use a paint pen or white pen to mark it.

1. Place the 24" Length of ABS pipe and a straight edge(ruler works fine) side by side on a flat surface. Push the pipe tight against the straight edge and mark the line where they touch. This is Line 1.
2. Tape 3 sheets of 8.5x11 paper together, so that they form a long, completely straight piece of paper. Wrap this around the section of pipe at each of the two the marks you just made, one then the other. Make sure the short side of the paper is straight along Line A and the paper is straight against itself where it overlaps. Mark a line along the edge of the paper at each end. Call one Line 2 and the other Line 3.
3. Start where Line 1 intersects Line 2. Going left around Line 2, make a mark at every 5 ½". The last section should be only be about 4 ½".
4. Start where Line 1 intersects Line 3. Going right around Line 3, make a mark at every 5 ½".
5. Mark each line using a straight edge.
6. Cut along these lines, using the jigsaw or band saw. I recommend a speed

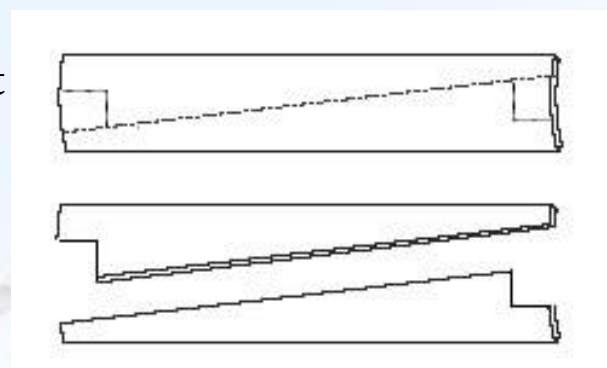
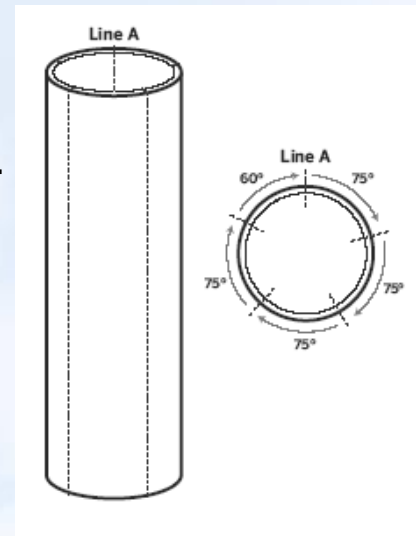

controlled jigsaw so you don't melt the plastic as you are cutting it. You should get 4 blades, 3 blades 5 1/2" and on small scrap.

7. I recommend cutting a notch for bolting it, at least 1 1/2" in width and 1 1/2" long.

Step 3: Sanding the Blades

Although by the angle they were cut creates an airfoil, you should sand the blades to achieve an even better airfoil. This will increase the efficiency of the blades and making them quieter. The angled (leading) edge wants to be rounded, while the straight (trailing) edge wants to be pointed. Any sharp corners should be slightly rounded to cut down on noise.

Step 4: Getting Blades on to the Hub

My treadmill motor came with the hub attached. This hub unscrews clockwise, which is why the

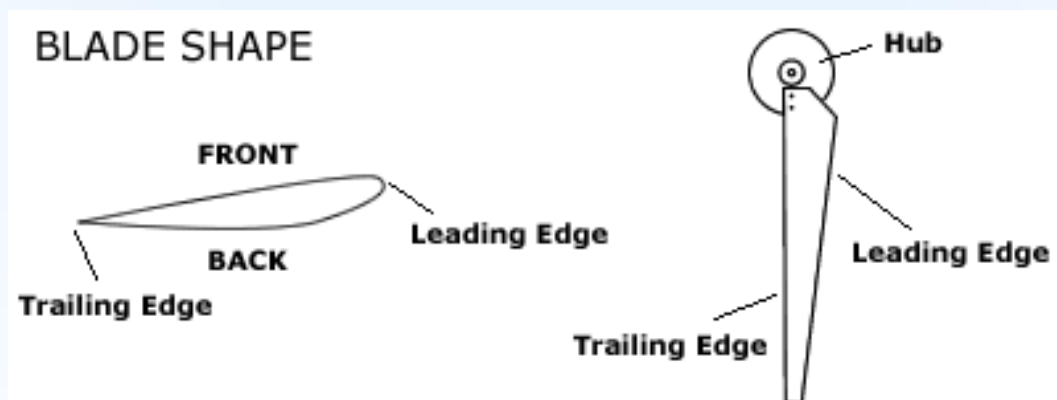
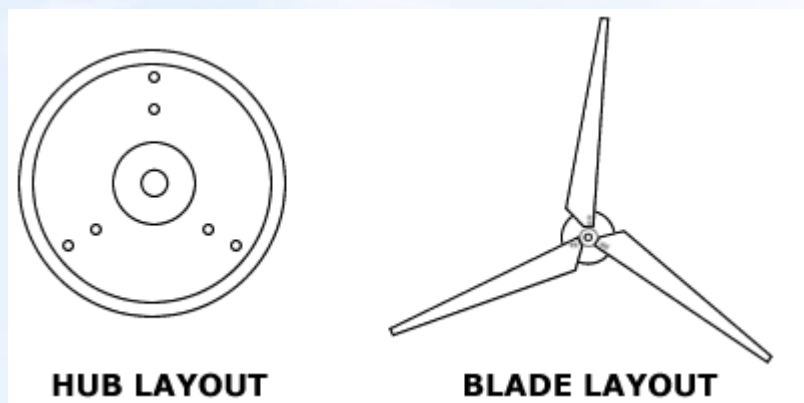

blades turn counter-clockwise.

se. My hub has cooling fins which made it harder to bolt to it. Since

I recommend sealing the motor completely I would just grind them flat (if you remove cooling fins then the current rating for the motor will be lower).

1. Make a template of the hub on a piece of paper, using a compass and protractor.
2. Mark 3 holes, each about 3" from the center of the circle and equal distance from each other.
3. Place this template over the hub and punch a starter hole through the paper and onto the hub at each hole.
4. Drill these holes to the size of your choice, I would recommend $\frac{1}{4}$ " to $\frac{3}{8}$ ".
5. If you are good at tapping holes then I recommend tapping, if not just use nuts. Make sure you at least a lock washer to keep them secure.
6. Bolt the blades onto the Hub. At this point, the outer holes have not been drilled.
7. Measure the distance between the straight edge of the tips of each blade. Adjust them so that they are all an equal distance from each other. Mark and punch each hole on the hub through the empty hole in each blade.
8. Label the blades and hub so that you can match which blade goes where.
9. Remove the blades and then drill and tap these outer three holes.
10. Bolt the blades back on, and you're done.



Step 5: Protect the Generator

I recommend making some kind of protection sleeve or enclosure to protect your motor. A PVC pipe that is large enough to fit your motor will work fine. I used some very light gauge aluminum and RTV and made a little motor enclosure. I found both at my hardware store. I also made cut outs of the aluminum and put them front and back then sealed them with RTV.

Step 6: Mount and Tail

The mount and tail should be sturdy. Weld the mount to the yaw pipe, if at all possible. Also, make sure your tail is on there good. If it vibrates, then add a bolt that goes all the way through the mount.



I purchased a 1x1 inch square stainless tube for my base. You can also use aluminum or cheap steel if you paint it. My motor had two mounting spots on it and I decided to use them, I just took it to my local hardware store and purchased the right size bolts.

Drilled the holes into my square tube and bolted it together. If you don't have good mounting holes I recommend purchasing large U-bolts or good hose clamps to mount it to the base. You may want to make your protective sleeve over you mountings too.

Tails are not a big deal, but the bigger the better. It needs to be square with the blades, so it points them straight on into the wind. I purchased a small square of sheet metal about 20 gauge and cut it into my desired shape of a tail and used sheet metal screws to attach it to the base.

You can pretty much use anything you want but I would recommend plastic or metal. Don't get something too flimsy that

will make noise and wiggle your wind turbine when it's blowing. The 20 gauge sheet will wiggle and make some noise in high winds and I would recommend something thicker. 1/8 acrylic (Plexiglas) should do if you keep it small.

When placing your mount to the base make sure that it will be balanced. You need some way of making your mount be able to swivel. There are lots of different things you can use. I went to the plumbing department and found a floor flange for 1 3/4 pipe made out of heavy pot steel, and then I found a swivel pipe unioner to allow the turbine to yaw. I bolted the flange to the base.

To make the unioner swivel I just greased the inside and then used some JB weld to hold the parts together enough to move but not come apart and allowed to cure. I used a nipple to attach the unioner to my flange and then the flange would screw into my tower.

Step 7: Balancing your blades

Before getting ready to put your wind turbine out, balance your blades. This will stop vibration, noise, and make your wind turbine more efficient at turning wind power into electricity. You can easily do this by placing the turbine on a flat, level table.

Spin the rotor with the blades on it, if one blade is heavier or slightly out of place than the others it should fall to the bottom. Lightly trim the end or give additional sanding until all blades are even and balanced. If you have a real balance I would recommend using it, but if not this way will you can get it close, really depends on how nice your bearings are in the motor.

Step 8: Set up the Tower

Make your tower good and strong. I used some scrap 1 3/4 inch water pipe which was treaded so it was easy to simply screw together. Bury your tower and cement the base and then install guy wire, the rule of thumb is every 15ft of tow you need guy wires twice the height on the tower it being attached.

Choose the Guyed Tower

A guyed tower has a center mast (pole) with guy wires supporting and holding it in place. These towers are typically the easiest and cheapest to build and the most popular by home wind turbine builders. The mast takes all the vertical force of the wind turbine, mainly the weight of mast itself plus the wind turbine. The guy wires support all the horizontal force that the wind is applying to the turbine and tower.

The Mast

Mast are typically be made out of steel, commonly water pipe or tube is used because of its accessibility. Steel tubing that is used for water pipe is easy to find, work with, light, easy to cut, drill, and weld. Using hollow tubing also allows you to run the cables from the wind turbine inside the tower.

Dumps, recycling centers, salvage yards, and scrap yards are a good source of steel pipe. Pipe that has been threaded has been weakened, I recommend welding the pipes together verse threading them. I personally have used the threads of 1 3/4 in pipe before on smaller 4 FT rotor turbine with no trouble, but I am not going to recommended it.

Here is a chart that is for general information only, giving you an idea of the smallest pipe size to use.

Turbine Rotor Size	Steel Pipe Size
3 FT	1 ½"
6 FT	2"
9 FT	4"
12 FT	6"

If you are going to use something else than steel tubing, then review the strength of the material and ensure it will support the weight of the tower and be easy to work with. The tower will also have a torsion force on it between the ground and each individual level that the guyed wires attach to. That force can be calculated with a little physics and basic geometry.

Tower Hinge

A hinge for tilt-up tower is an important part. It must be able to withstand the day to day force and put up with the abuse of rising and lower the entire weight of the tower and turbine. I always recommend a concrete foundation and either embedded part of your hinge in the concrete foundation or properly bolting it to the foundation.

The hinge does not have to be complex in design, it can be as simple as two base plates and two tower plates with center holes drilled that a locking pin fits into that can support the entire weight of the tower and also allow it to pivot.

Do not be shy on the size of mounting bolts and the Locking Pin. Use ½" or larger 1" bolt embedded at least 5" in the reinforced concrete, using undersized bolts could be catastrophic. The same goes for the Locking Pin, use ½" steel or larger, you can use a partially threaded bolt or a real locking pin, I do not recommend rod stock unless you can rivet the ends.

Gin Pole

Some tilt up towers have what is known as gin pole, which is perpendicular of the main mast. This arm is used to help lift the tower off the ground.

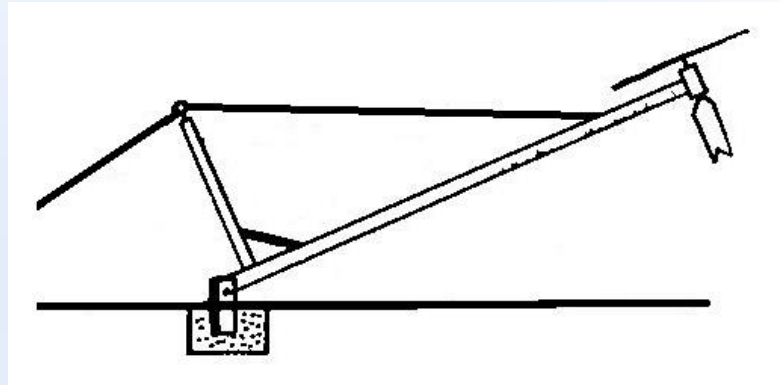

Usually it is a steel pipe of the same diameter as the tubular tower pipe. The longer the gin pole, the easier it is to lift the tower. A gin pole makes it much easier to raise the tower but not completely necessary.

Guy Wires

Guy wires will support the stresses from the wind pressing on the turbine and any other horizontal force the tower or turbine receives. Guy wires are typically stranded metal cables. You can purchase 3/16" galvanized wire rope from most hardware stores which will work excellent for most towers. If you are installing the turbine in a temporary position then standard rope can be acceptable instead of metal cables.

You should put three or four guy wires per layer evenly spaced around the tower. Each layer should not be any further than 18ft between each layer or 18ft from top or bottom of the tower. If your tower is twenty feet tall, you would want one layer of guy wires at 18ft, if your tower was thirty feet tall, you would want one layer at 12ft and another layer at 25ft.

The distance of the guy wire anchors should be at least half the distance from the base as it is the distance up the tower. Example:

Your first set of guy wires is attached to the tower at 18 FT and then you would want your anchor to be placed at least 9ft from the base of the tower.

Anchors

Concrete blocks

The best anchor is a large block of reinforced concrete in the ground, it also looks very professional. You can use ready mix and some pieces of rebar. You should calculate how much weight you want for the support of your turbine. Eye bolts should be embedded to attach the guy wires to.

A Dead Man

A dead man is a deep buried object and is an excellent cheap anchor. Rope or any other corrodible material should not be used below the ground. You will need some kind of riser, a stainless steel bolt or chains are good options.

Dig a hole and bury a piece of steel pipe, treated lumber, or anything you can find that will not degrade over time. The depth will depend on the forces involved, the type of ground you have, and the size of the dead man, but at least two feet down. You need to give time for the ground to settle before using it as anchor. Please also note it is not a good idea to use an actual dead person as the anchor, they will degrade to fast, and prison time might interfere with your wind turbine project.

Posts and stakes

For small wind turbines you can get away with posts or large stakes to use as guides. You must have good soil for holding the stakes in. Stakes must be driven at a perpendicular angle from the path of the guy wire.

Yawing

The most common yaw 'bearing' is by slipping a larger size of tube over the end of the tower tube or the other way around. They must be snug to each other but still be able to move freely. Depending on your design, you might have to weld a plate on the top of or the bottom of the mount to keep the two tubes in together. The cable can hang down the middle of the tube of the tower.

There are more ways to build your yawing bearing than the two tube method, however, I do find it simple, easy, effective, and cheap. There are a variety of off the shelf items that can be purchased to work as well.

Also creativity can really come into play here. My first yaw mount that I made was using a pipe unioner. I unscrewed one of the sides from the unioner and applied thick waterproof grease to the inside on the flange of the other side.

Loosely tighten the side that was previously removed, this should allow the opposite side to still spin freely. Apply JB Weld around the screwed side and allow to harden. Once finished you should have a perfect yaw mount. This unit will not last forever but should have many years of life, depending on condition.

Step 9: Wiring the system

You need to get the electricity out of the motor and off the tower, select a proper gauge of wire and run it down or inside your tower



and connect it to your wind turbine.

Step 10: Connect the batteries and charge controller

Now that you have all the mechanical parts sorted out, it's time to turn toward the electronic end of the project. A wind power system consists of the wind turbine, one or more batteries to store power produced by the turbine, a blocking diode to prevent power from the batteries being wasted spinning the motor/generator, a secondary load to dump power from the turbine into when the batteries are fully charged, and a charge controller to run everything.

Whether you build your own, or buy one, you will need some sort of controller for your wind turbine. The general principal behind the controller is that it monitors the voltage of the battery(s) in your system and either sends power from the turbine into the batteries to recharge them, or dumps the power from the turbine into a secondary load if the batteries are fully charged (to prevent over-charging and destroying the batteries).

In operation, the wind turbine is connected to the controller. Lines then run from the controller to the battery. All loads are taken directly from the battery. If the battery voltage drops below 11.9 volts, the controller switches the turbine power to charging the battery.

If the battery voltage rises to 14 volts, the controller switches to dumping the turbine power into the dummy load. There are trim pots to adjust the voltage levels at which the controller toggles back and forth between the two states.

Normally the system runs automatically. When charging the battery, the yellow LED is lit. When the battery is charged and power is being dumped to the dummy load, the green LED is lit. This gives you some minimal feedback on what is going on with the system. Use a multimeter to measure both battery voltage and turbine output voltage.

This photo shows the controller, battery and associated electronics all wired up. I have a 120V inverter connected to the battery and a multimeter to keep track of the battery voltage and wind turbine output voltage.

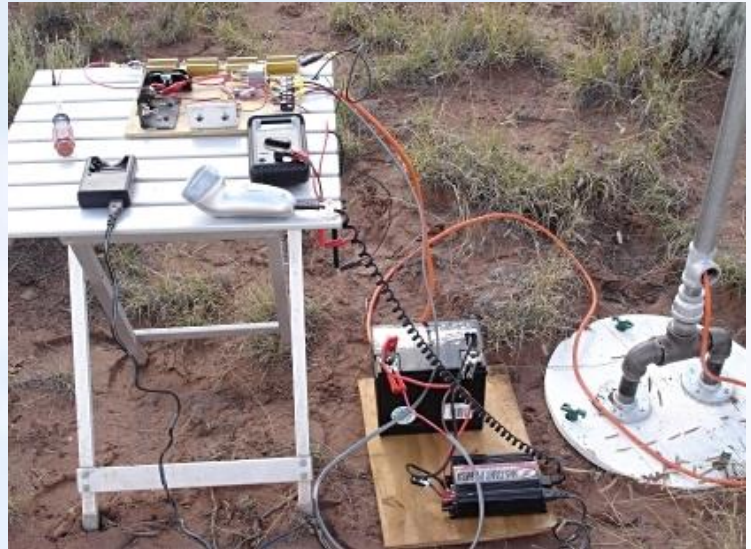

Final Thoughts

Maybe you're tired of paying ever-increasing electric bills and worried about the future availability of electricity as fossil fuels become depleted.

Maybe you've just bought land far away from the nearest power line and you'd like to harness some renewable power to pump water for your cattle.

Or maybe you're just a New Age entrepreneur who plans to generate electrical power at several windy sites and sell it to the utilities.

If any of these is true, you no longer have to worry about it. Wind power is here to stay and it's never been easier to use it for you and your family.

I want to thank you for reading this guide and for the support you have been showing for my work.

